

Stort utvalg av anleggsmaskiner

Vi har et bredt spekter av maskiner og tilbehør til anleggsbransjen. Vårt hovedfokus er tyngre anleggsmaskiner og utstyr.



SANY

Sany er et av de 500 største selskapene i verden med en markedsverdi på 130 milliarder kroner. Bedriften har et enormt varesortiment innen anleggsindustrien og er for eksempel verdens ledende produsent av betongpumper og beltegående kraner.

Maskiner fra Sany leveres til hele verden. De er verdens raskest voksende gravemaskinsmerke, og er for tiden verdens 6. største gravemaskinsprodusent.

Machine Partner AS er stolt forhandler av anleggsmaskiner fra Sany.

SY50U

SANY

Quality Changes the World



GREAT PERFORMANCE, SMALL PACKAGE

PHENOMENALLY AGILE. PHENOMENALLY EFFICIENT.

CONSTRUCTION MACHINERY



MINI EXCAVATORS
SY50U

Engine
Yanmar 4TNV88-
Rated power
PSY 29.1 kW / 2 400
Bucket capacity
rpm 0.152 m
Operating mass
5 300 kg

SANY

For challenging tasks,
you need a first-class partner

Quality comes from experience. And from new ideas. This is why we combine these two crucial factors at SANY. This is because we are one of the leading producers, having sold more than 450 000 excavators worldwide. This means that you can always rely on sophisticated products that have been tried and tested in practice. An impressive 5-7 % of our annual turnover is dedicated to research and development. This is why we give you not only our word, but also our extraordinary five-year warranty as a guarantee of how powerful and robust our products are.

450 000
EXCAVATORS SOLD
WORLDWIDE

5-7 %

TURNOVER FOR RESEARCH
AND DEVELOPMENT

**FIVE-YEAR
WARRANTY ***

Quality Changes the World

* Applicable in certain markets, please check with your local dealer.



SY50U HARD FACTS

Max. bucket digging force
32.5 kN (ISO)
Max. arm digging force
22.9 kN (ISO)
Swingspeed
10 rpm
Max. travel speed
4 km/h

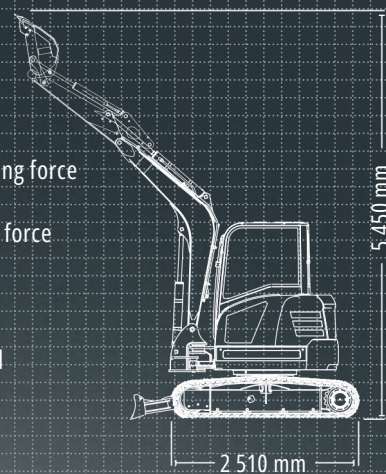



LIGHT WEIGHT, HEAVY DUTY

With the SY50U short-tail-swing excavator, you have a specialist at your side that can prove its rated power especially in confined spaces. It requires little space, so can work and manoeuvre everywhere where conventional machines reach their limits – in places that are difficult to access, directly next to walls and house walls, on construction sites in busy inner-city areas or on busy roads. You can rely on its responsive, precise control and on the fact that this small machine is ranked at the level of significantly larger machines in its class in terms of speed and rated power.



TOP PROPERTIES

ECONOMY

OPERATING COSTS DOWN, PRODUCTIVITY UP

The SY50U is equipped with a particularly effective load-sensing hydraulic system. The axial piston pumps with a variable flow rate ensure sufficient power to carry out all operations smoothly and safely. The well-balanced combination of speed, power and precise response behaviour guarantees high cost-effectiveness with fuel in every phase: The hydraulic pump always delivers just enough oil as is actually needed.



QUALITY

Robust and durable – Especially precise, robot-manufactured welded seams guarantee a long service life under the harshest conditions.



SAFETY

No compromises – Extensive safety equipment is standard: Beacon lamps, lockable protective hoods, a battery master switch and safety valves as standard on the arm and boom.

Absolute reliability – for peace of mind!

SANY's five-year warranty* gives you the assurance that you can fully count on your equipment.



* With participating partners

ECONOMY

Less is more

Quality that pays for itself in the long term: Low maintenance requirements and long intervals between maintenance. Additionally, all important maintenance points are very easily accessible. This saves on operating costs and increases cost-effectiveness.



DIMENSIONS

In the smallest of spaces – The short-tail-swing machine's compact dimensions enable it to manoeuvre masterfully even in the smallest areas of the construction site. This mobility broadens its possible applications and increases productivity.

USER EXPERIENCE

Maintenance and service – The engine bonnet is very easy to open with help from the gas pressure dampers. At the back, the key components for maintenance and service are clearly arranged in the centre. The radio with USB and Bluetooth interface offers improved working comfort.



COMPONENTS

Power – The tried-and-tested Yanmar 4TNV88 PSY engine guarantees reliable performance for all tasks, even in harsh working conditions.

ECONOMY

Cost-effectiveness as standard – The smart control system adapts the pump capacity to the available engine power for greater efficiency and reduced fuel consumption.



QUALITY Metal panels

Durability and robustness are standard features on all SANY excavators. For example, the panels are made solely of metal. This makes them particularly robust – and if an accident happens during the tough everyday work on a construction site, it can usually be straightened out again quickly.



EFFICIENCY, COST-EFFECTIVENESS AND USER EXPERIENCE

USER EXPERIENCE

A FOCUS ON THE OPERATOR

The productivity of an excavator is largely dependent on whether the driver can work for long periods in a focused manner. This is why the SY50U is fitted with a particularly roomy driver's cab with the highest level of comfort. The operator can sit comfortably in the ergonomic driver's seat. The height of the armrests can be adapted for fatigue-free working. Despite the compact design, there is also enough room in the footwell – if required, the pedals can be folded away to create more space. The driver has the best possible view of everything from the cab. The quiet-running engine, together with the sound- and vibration-damping design, minimises noise and vibrations. Another detail is the split floor mat, which is easy to pull out for fuss-free cleaning.



USER EXPERIENCE

For a full view

You have everything in view with the large, central display, which shows all important data and values clearly and well arranged. In addition to the basic information, gear selection or attachment device can also be set here. The next planned maintenance is also stored in the menu.



USER EXPERIENCE

Easy-maintenance concept

Machines that are quick and easy to maintain save time and money day-to-day on the construction site. The SANY SY50U provides easy access to all points necessary for checking and maintenance work straight from the ground. This means that planned maintenance can be carried out quickly from groundlevel, which increases the machine's availability and service life and ensures that both the operators and the equipment are reliably protected in the long term.

Our highlights – the added benefits SANY offers you:

- + 2 proportional auxiliary line on joystick as standard
- + Double acting circuit for hydraulic quick coupler with piping
- + Efficient, powerful load-sensing hydraulic system
- + Auto Idle
- + Air conditioning
- + Safety valves on arm and boom
- +



COMPONENTS

MORE LIGHT, MORE VISIBILITY, MORE SAFETY

With the SY50U, you can always see what you're working on, even in poor visibility. The powerful LED light's guarantee that the work area is optimally illuminated. Their energy usage is pleasingly low, ensuring that the battery has a long service life. Furthermore, the headlights require almost no maintenance, which saves time and repair costs.

DIMENSIONS

Quick look round the back

Excavation operations next to obstacles? No problem for the SANY SY50U. With the compact short-tail-swing excavator, you can enjoy the highest degree of manoeuvrability, as well as unlimited rotation.



SAFETY

Optimum panoramic view

The large windows and sophisticated cab design ensure that the driver has the best possible view of the area around the vehicle. The 360° panoramic view allows exceptional safety levels in the working area.

TECHNICAL SPECIFICATIONS

ENGINE

Model	Yanmar 4TNV88-PSY
Typ	Water-cooled, 4 cylinder, with commonrail and DPF
Exhaust emissions	Stage V
Rated power	29.1 kW / 2400 rpm
Max. torque	144.9 Nm / 1500 rpm
Displacement	2190 ccm
Batteries	1 × 12 V / 120 Ah

HYDRAULIC SYSTEM

Mainpump	Variable displacement axial piston pump
Max. oilflow	138.6 l/min
Travelmotor	Variable displacement axial piston motor
Swingmotor	Axial piston motor
Max. oilflow (AUX 1)	80 l/min
Max. oilflow (AUX 2)	45 l/min

SERVICE REFILL CAPACITIES

Fuel tank	78 l
Engine coolant	4.2 l
Engine oil	7.4 l
Drive (per side)	0.9 l
Hydraulicsystem	80 l
Hydraulic oil tank	52 l

PERFORMANCE

Swingspeed	10 rpm
Max. travel speed	High 4 km/h, slow 2.7 km/h
Max. travel force	40.7 kN
Gradeability	30°
Bucket capacity	0.152 m ³
Groundpressure	0.32 kg/cm ²
Bucket digging force ISO	32.5 kN
Arm digging force ISO	22.9 kN

OPERATING MASS

SY50U	5300 kg
-------	---------

UNDERCARRIAGE AND UPPER STRUCTURE

Boom length	2700 mm
Arm length	1500 mm
Bottomrollers	4
Toprollers	1
Rotation device	Planetary gear reducer driven by an axial piston motor, automatic hydraulic released slewing brake

RELIEF VALVE SETTINGS

Implement circuit	245 bar
Swing circuit	191 bar
Travel circuit	245 bar
Pilot pressure	35 bar

LIFTING CAPACITIES OF LOWER DOZER BLADE

Load point height	Radius				Digging reach	
	2.0 m	3.0 m	4.0 m	5.0 m	Capacity	mm
4.0 m kg					1085	845 3905
3.0 m kg	1050 815				1050	655 4605
2.0 m kg	1545	1190	1190	790	1055	580 4948
1.0 m kg	2020	1110	1365	760 1080	560	1075 555 5024
Ground line kg	2165	1075	1445	735	1100	575 4849
-1.0 m kg	2735	2000	1975	1075 1325	735	1110 655 4385
-2.0 m kg	2135	2050	1370	1100	1040	905 3476

LIFTING CAPACITIES OF UPPER DOZER BLADE

Load point height	Radius				Digging reach	
	2.0 m	3.0 m	4.0 m	5.0 m	Capacity	mm
4.0 m kg					1025	845 3905
3.0 m kg	985 815				790	655 4605
2.0 m kg	1485	1190	960	790	700	580 4948
1.0 m kg	1400	1110	925	760 680	560	675 555 5024
Ground line kg	1360	1075	905	735	700	575 4849
-1.0 m kg	2735	2000	1355	1075 900	735	800 655 4385
-2.0 m kg	2135	2050	1370	1100	1040	905 3476

DIMENSIONS (TRANSPORT)

A	Transport length	5390 mm
B	Transport width	1960 mm
C	Overall width of upper structure	1760 mm
D	Height over cabin/ROPS	2630 mm
E	Height of Boom – transport	2060 mm
F	Overall length of crawler	2510 mm
G	Tail length	980 mm
H	Track gauge	1560 mm
I	Undercarriage width (blade)	1960 mm
J	Horizontal distance to blade	1790 mm
K	Blade height	340 mm
L	Track height	610 mm
M	Track pads width	400 mm
N	Min. ground clearance	325 mm
O	Counterweight clearance	675 mm
P	Engine cover height	1660 mm
Q	Tail swing radius	980 mm
R	Center distance of tumbler	1970 mm

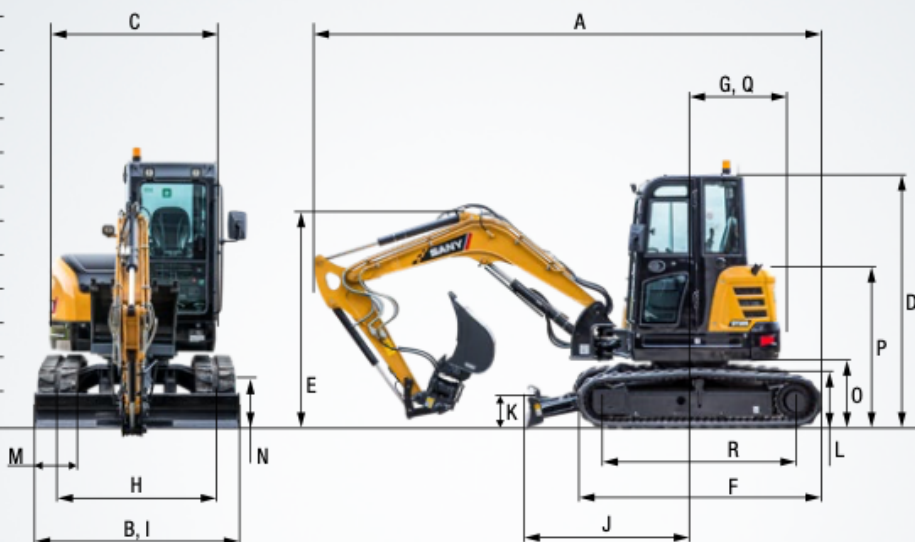

WORKING AREA

A	Max. digging reach	5880 mm
B	Max. digging depth	3420 mm
C	Max. digging height	5450 mm
D	Max. dumping height	3805 mm
E	Min. dumping height	1410 mm
F	Max. vertical digging depth	2460 mm
G	Overall height over arm by min. swing radius	4155 mm
H	Arm head distance with work equipment retracted as far as possible	1690 mm
I	Swing radius by max. boomswing (L)	2260 mm
	Swing radius by max. boomswing (R)	2080 mm
	Min. swing radius	2520 mm
J	Max. clearance when blade up	420 mm
K	Max. depth of blade down	405 mm
L	Offset boom (L)	745 mm
	Offset boom (R)	710 mm
	Max. boom-swing angle (L)	58°
	Max. boom-swing angle (R)	54°

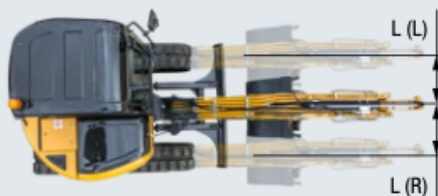
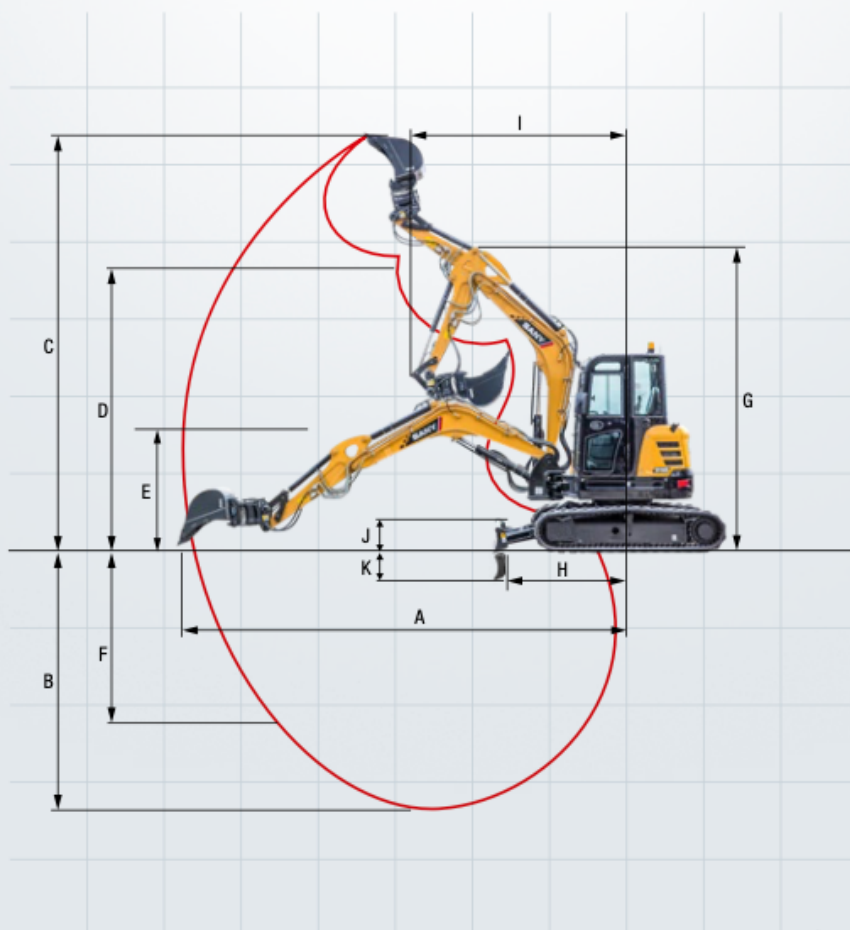

The SY50U – great results and great equipment

The SY50U ex-works is an all-rounder and perfectly equipped for a range of applications. Optional extra equipment and attachment devices are available to increase its flexibility even more.



OPERATORS COMFORT / CABINE

Heater	•
Manual air condition system*	•
USB/Bluetooth Radio	•
Armrests (adjustable)	•
12v outlets	•
Wiper	•
Sprayer f. wiper	•
AUX 1 on joystick	•
AUX 2 on joystick	•
8 stored hydraulic settings for attachments	•
Removable front-window	•

SAFETY

Battery master switch	•
Travel Alarm	•
Warning beacon	•
Emergency lowering	•
Lockable hoods	•

HYDRAULIC SYSTEM

Swing brake	•
2 speed travel	•
Hydr. Pre-pressure operating joysticks	•
Piping for additional hydraulic function AUX 1	•
Piping for additional hydraulic function AUX 2	•
End position damping on boom and arm cylinder	•

WORKING LIGHTS

Lights – front (LED)	•
Lights – boom (LED)	•

UNDERCARRIAGE

Rubber tracks	•
Holes/loops for fixing	•
Cylinder guardes – dozer blade	•

ENGINE/ENGINE COMPARTMENT

Auto idle	•
Diesel filter	•
DPF	•
Airfilter	•

WORKING EQUIPMENT

Boom and arm load holding valves with overload indicator	•
Double acting circuit for hydraulic quick coupler with piping	•
Breaker&Shear line proportional on Joystick with piping	•
Rotation line proportional on Joystick with piping	•
Flow adjustment for attachments	•
Dozer blade	•
Cylinder guardes – boom	•
Safety valve on dozer blade	•

• Standard equipment Special option •

The standard and special options differ depending on the country in which the crawler excavator is delivered. If you have any questions, please contact your dealer directly. * The air conditioner contains fluorinated greenhouse gases: Refrigerant type: HFC-134a, Global warming potential: 1 430, Quantity: 0.625 kg, CO2e: 0.89 t

Parts supply – quick and reliable

With the purchase of a SANY mini excavator you have made an investment in the future. Fast availability of spare parts is your guarantee of minimal downtimes and failure times.



A SERVICE YOU CAN RELY ON

Just as we do with our excavators, we also demand high quality and reliability of our service products. This underlines our equipment's performance in terms of their durability and their excellent price-performance ratio. After all, maintenance is crucial

for efficiency, cost-effectiveness and safety. Your SANY dealer is happy to help you with a comprehensive range of services to ensure that your machine continues operating efficiently in the long term.

SANY – flexible, fast and always there for you

Rapid assistance, tailored advice and a reliable supply of original parts – that is what we mean by a premium service.



The added benefits SANY offers you:

- + Fast supply thanks to the central warehouse near Cologne
- + More than 15,000 spare parts to make your machine highly reliable
- + Expert knowledge for optimal supply for your machine
- + Thanks to SANY's special training programme, our dealers are always kept up-to-date so that they can face all technical challenges.

Detailed information in black and white

Handbooks and documents are available for all SANY mini excavators, and these can help you with operation, maintenance, servicing and repairs. These include operating and maintenance instructions and technical specifications.



HIGHLIGHTS **SY50U**



PERFECT COMBINATION OF COMPACTNESS + AND POWER

The SANY SY50U really is a powerful little machine. Its compact design means it is at home on urban construction sites, as well as anywhere with areas that are particularly small. Its performance and extensive standard equipment guarantee high productivity.

ROBUST AND DURABLE

All components are designed to withstand high stress. The workmanship of the materials is also especially **high-quality** – almost all the **welded seams are perfectly executed by welding robots**.

IN THE SMALLEST OF SPACES

The **robust swivel bracket** is the most important aspect for all tasks. It enables the machine to achieve its exceptionally **compact mobility**.

MAINTENANCE AND SERVICE

Thanks to the engine bonnet supported by **gas pressure dampers** and the central, **clear arrangement of the key components**, usual routine checks and work on the machine can be carried out quickly and easily.

NO COMPROMISES

Daily operations on the construction site make high demands on both operators and machines. **High-quality safety components** are therefore always a must, for example the **sturdy cylinder covers** and the **two proportional auxiliary lines with joystick operation as standard**.

POWER

The **powerful Yanmar 4TNV88 PSY engine** means that this mini excavator is also perfectly suited to „maxi“ tasks.

COST-EFFECTIVENESS AS STANDARD

In conjunction with the **electronic fuel injection**, the **autothrottle function** adjusts the engine speed to the power required. This means that the **smart hydraulic system reduces the fuel consumption, engine wear and exhaust emissions**. This is positively reflected in its cost-effectiveness and **low life cycle costs**.

TECHNICAL HIGHLIGHTS

Engine	Yanmar 4TNV88-PSY
Rated power	29.1 kW / 2 400 rpm
Max. torque	144.9 Nm / 1 500 rpm
Max. travel speed	4 km/h
Swingspeed	10 rpm
Mainpump	Variable displ. axial piston pump
Max. oilflow	138.6 l/min



**„TOP PERFORMANCE –
IT JUST DOES IT WELL!“**

Jens Gans (machine operator) –
Straßen- und Tiefbau GmbH, Eilenburg, Germany

Not all products are available in all markets. As part of our continuous improvement process, we reserve the right to modify specifications and designs without giving prior notice. The figures may contain additional options.

